

## Overview of LA2Xi, LA4X, LA12X, and LA7.16i features for integration with Voice Alarm systems

### General layout

Comprehensive monitoring for integration of an L-Acoustics system with a Voice Alarm system requires:

- a third-party Central Control Unit (CCU, for example Crestron, Q-SYS, Extron, etc.) supporting the L-Acoustics L-COM protocol, or SNMP
- on-site calibration of nominal system conditions and failure state conditions

### General layout

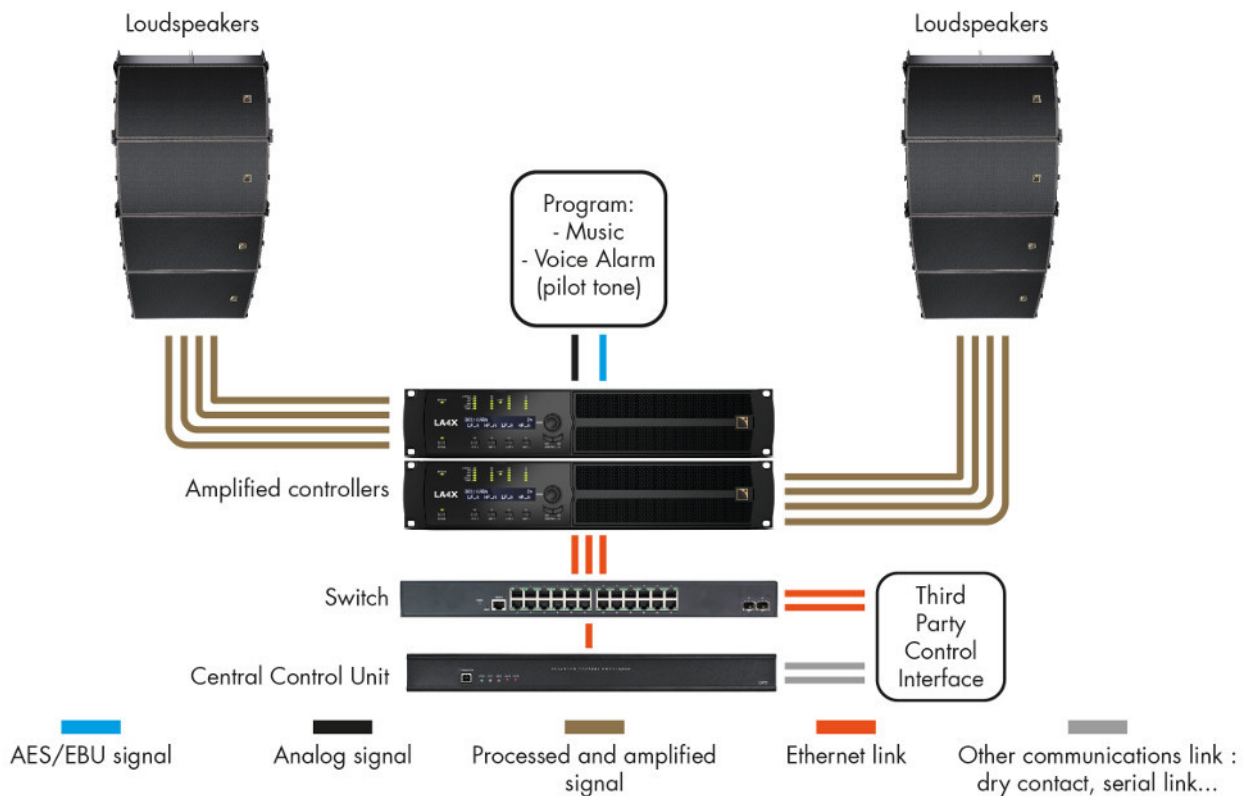

Crestron is a trademark or registered trademark of Crestron Electronics, Inc. in the United States, other countries or both.

Extron is a registered trademark of Extron Electronics.

QSC® and Q-SYS™ are trademarks or registered trademarks of QSC, LLC in the U.S. Patent and Trademark Office and other countries.

## System monitoring

System monitoring provided by LA2Xi, LA4X, LA12X, and LA7.16i amplified controllers.

function	LA2Xi	LA4X	LA12X	LA7.16i
Real-time load presence and short-circuit detection on output channel	Yes <sup>1</sup>	Yes <sup>1</sup>	Yes <sup>1</sup>	Yes <sup>1</sup>
Periodic silent test of output circuit	Yes	Yes	Yes	Yes
AES/EBU input signal presence and error detection	Yes	Yes	Yes	Yes
Pilot tone detection on active inputs	Yes	Yes	Yes	Yes
Power amplifier failure detection	Yes	Yes	Yes	Yes
Power supply failure detection	Ext <sup>2</sup>	Ext <sup>2</sup>	Yes	Yes

## Ethernet control network

Ethernet control network for LA2Xi, LA4X, LA12X, and LA7.16i amplified controllers.

	LA2Xi	LA4X	LA12X	LA7.16i
<b>type of network</b>	Local Area Network with up to 253 amplified controllers			
<b>Ethernet ports</b>	two, up to 1 Gb/s			
<b>cabling</b>	CAT5e cable (or higher), max length = 100 m / 328 ft <sup>3</sup> , RJ45 connectors			

<sup>1</sup> On condition that output delivers at least 1 W / 4 Ω

<sup>2</sup> To be periodically tested by Central Control Unit

<sup>3</sup> Typical. May be extended using third-party fiber optic interfaces.

## Power statuses and cascaded links

Consequences of power statuses on cascaded links.

<b>amplified controller</b>	<b>link</b>	<b>powered on and idle</b>	<b>standby</b>	<b>powered off</b>	<b>power cord removed</b>
<b>LA2Xi</b>	AVB/Ethernet	refreshed	refreshed	n/a	refreshed <sup>4</sup>
	AES/EBU	refreshed	refreshed	n/a	ok
	analog	ok	ok	n/a	ok
<b>LA4X</b>	AVB/Ethernet	refreshed	refreshed	interrupted	interrupted
	AES/EBU	refreshed	refreshed	ok	ok
	analog	ok	ok	ok	ok
<b>LA12X</b>	AVB/Ethernet	refreshed	refreshed	interrupted	interrupted
	AES/EBU	refreshed	refreshed	ok	ok
	analog	ok	ok	ok	ok
<b>LA7.16i</b>	AVB/Ethernet	refreshed	refreshed	n/a	refreshed <sup>4</sup>
	AES/EBU	refreshed	refreshed	n/a	ok
	analog	ok	ok	n/a	ok

<sup>4</sup> When 24 V DC power is present. If not, Ethernet is interrupted.

## Signal inputs

Signal inputs of LA2Xi, LA4X, LA12X, and LA7.16i amplified controllers.

	<b>LA4X</b>	<b>LA12X</b>	<b>LA2Xi</b>	<b>LA7.16i</b>
<b>analog audio inputs</b>	4 balanced analog inputs line level up to +22 dBu 4 female XLR connectors 4 male XLR for passive link		4 balanced analog inputs line level up to +22 dBu 4 × 3-pin terminal block connectors External passive linking is possible	1 balanced analog input <sup>5</sup> with passive link line level up to +22 dBu 1 × 12-pin terminal block connector
<b>digital audio inputs</b>	2 AES/EBU inputs (110 Ω) 2 female XLR, shared with analog inputs 1 and 3 2 male XLR for active link with failover relay, shared with analog links 1 and 3		2 AES/EBU inputs (110 Ω) 2 × 3-pin terminal block connectors, shared with analog inputs 1 and 3 2 × 3-pin terminal block connectors for active link with failover relay	1 AES/EBU input <sup>5</sup> (110 Ω) with active link with failover relay 1 × 12-pin terminal block connector
<b>simultaneously active inputs</b>	up to 4, analog or digital, selection by pair			up to 16, analog or digital, selection by individual input channel
<b>AVB digital audio inputs</b>	4 channels 48 kHz / 96 kHz from 1 AVB stream of up to 8 channels	AVB input with support of Milan seamless dual networking 4 channels 48 kHz / 96 kHz from 1 AVB stream of up to 8 channels		AVB input with support of Milan seamless dual networking 16 channels 48 kHz / 96 kHz from 16 AVB streams of up to 8 channels
<b>input mixing</b>	yes: by pair, sum or difference of the channels of the active inputs			yes: sum or difference of any channels of the active inputs
<b>analog cabling</b>	recommended maximum length: up to 100 m / 328 ft (typical) recommended maximum number of cascaded links: 22			
<b>digital cabling</b>	tested max. length: 305 m / 1000 ft (at Fs = 48 kHz) with selected AES/EBU rated cables recommended maximum number of cascaded links: 22			

<sup>5</sup> The analog and AES/EBU inputs and links share the same terminal block pins on LA7.16i, so either one or the other input type can be used at once.

## Automatic fallback

The AVB automatic fallback feature allows for input signal redundancy where AVB is used as a primary signal, and AES/EBU or analog inputs are used as a backup signal. In case of error, the input mode instantaneously switches over to the fallback inputs.

In case when Milan seamless redundancy is used, an error on one of the redundant AVB networks causes no audio interruption.

Additionally, the AES/EBU automatic fallback feature allows for input signal redundancy where AES/EBU is used as primary signal. In case of error, the input mode instantaneously switches over to the fallback input (secondary AES/EBU or analog input (less than 135 ms of audio interruption)).

<b>automatic fallback mode (built-in)</b>	<b>LA2Xi</b>	<b>LA4X</b>	<b>LA12X</b>	<b>LA7.16i</b>
<b>Milan seamless redundancy</b>	yes	no	yes	yes
<b>AVB to AES/EBU or analog</b>	yes, 4 channels			yes, 16 channels
<b>AES/EBU to analog</b>	yes, 2 channels			no
<b>AES/EBU to AES/EBU</b>	yes, 2 channels			no

Alternative modes where analog is used as a primary signal may be implemented by integrators based on pilot tone detection and input selection management by Central Control Unit:

<b>programmable fallback mode (managed by CCU)</b>	<b>LA2Xi</b>	<b>LA4X</b>	<b>LA12X</b>	<b>LA7.16i</b>
<b>analog to AES/EBU</b>	yes, 2 channels			no
<b>analog to analog</b>	yes, 2 channels			no

## Status change time

	<b>LA2Xi</b>	<b>LA4X</b>	<b>LA12X</b>	<b>LA7.16i</b>
<b>OFF to ON</b>	7 s	5 s	9 s	13 s
<b>STANDBY to ON</b>	2 s	5 s	5 s	9 s
<b>DC24V to ON</b>	1.5 s	-	-	9.5 s
<b>ON to STANDBY</b>	< 0.5 s	< 0.5 s	< 0.5 s	< 0.5 s
<b>ON to OFF</b>	< 0.5 s	< 1.5 s	approx. 20 s <sup>6</sup>	8 s <sup>6</sup>

<sup>6</sup> Audio instantaneously cut when switching to OFF.

## Power and UPS sizing

This table presents the power consumption for each amplified controller for a typical musical program in nominal conditions, in idle mode, and in standby mode, for various nominal loads and with 230 V mains.

The calculator is available at [www.l-acoustics.com/installation-tools/](http://www.l-acoustics.com/installation-tools/).

		1/8 max power (-9dB)			idle		standby	
amp	all ch. loaded at	current draw (A)	thermal load (W)	thermal load (BTU/hr)	current draw (A)	thermal load (W)	current draw (A)	thermal load (W)
<b>LA2Xi</b>	4 Ω in SE or PBTL mode, or 8 Ω in BTL mode	2.3 A	110 W	375 BTU/hr	0.5 A	27 W	0.4 A	16 W
	8 Ω in SE mode	1.6 A	80 W	273 BTU/hr	0.5 A	27 W	0.4 A	16 W
	16 Ω in SE mode	1.2 A	55 W	188 BTU/hr	0.5 A	27 W	0.4 A	16 W
<b>LA4X</b>	4 or 8 Ω	3 A	250 W	853 BTU/hr	0.9 A	60 W	0.7 A	11 W
<b>LA12X</b>	2.7 Ω	11.5 A	750 W	2559 BTU/hr	1 A	141 W	0.6 A	10 W
	4 Ω	8.1 A	550 W	1877 BTU/hr	1 A	141 W	0.6 A	10 W
	8 Ω	4.8 A	350 W	1194 BTU/hr	1 A	141 W	0.6 A	10 W
<b>LA7.16i</b>	4 Ω	13 A	900 W	3071 BTU/hr	1.2 A	215 W	0.7 A	18 W
	8 Ω	11.2 A	660 W	2252 BTU/hr	1.2 A	215 W	0.7 A	18 W

## Third-party control systems

Functions available from third-party control systems using L-COM protocol or SNMP.

status information and monitoring (read only)	commands (write)
<ul style="list-style-type: none"> <li>• amplified controller type</li> <li>• current operating mode: standby, active</li> <li>• full reporting of errors</li> <li>• current input mode and status, fallback status</li> <li>• current preset name, family, output names</li> <li>• name of next available preset</li> <li>• signal level / limit / clip</li> <li>• front panel keys locked/unlocked</li> </ul>	<ul style="list-style-type: none"> <li>• standby / wake-up</li> <li>• input mode selection</li> <li>• preset load</li> <li>• mute/unmute, output gain control</li> <li>• lock/unlock front panel keys</li> <li>• output gain</li> </ul>

## Settings protection

In order to ensure the integrity of a fire alarm system, access to the amplified controllers parameters has to be restricted. These parameters can be protected independently from:

- LA Network Manager and amplified controller front panel access
- third-party control system application using a specifically determined access policy

Settings Protection is based on three levels of users.

When Settings Protection is enabled by the Administrator:

only the Administrator can	the Advanced User can (with the PIN code)	the General User can
<ul style="list-style-type: none"> <li>• load non-authorized Session files</li> <li>• delete a user preset</li> <li>• reset Units to factory default parameters</li> <li>• update firmware</li> <li>• use quick access to gain from front panel</li> </ul>	<ul style="list-style-type: none"> <li>• load a factory preset</li> <li>• store a preset</li> <li>• modify any group parameter</li> <li>• modify a preset parameter</li> <li>• access M1</li> <li>• modify the IP address of a Unit</li> </ul>	<ul style="list-style-type: none"> <li>• load authorized Session files</li> <li>• restore Session</li> <li>• load user presets</li> <li>• select the input mode</li> <li>• mute/solo</li> <li>• set in standby / wake-up</li> </ul>

Access rights have been defined by L-Acoustics to meet the needs of 90% of the fixed installation applications. This policy cannot be modified by the Administrator.

For any specific need please contact L-Acoustics Application Team ([applications@l-acoustics.com](mailto:applications@l-acoustics.com)).

# Appendix

## Rear connection panels

The amplified controller's rear side features connectors for audio and network cabling:

1. For connection to the loudspeakers.
2. For connection of the analog and/or digital (AES/EBU or S/PDIF) audio sources, and/or for linking the signals to another amplified controller.
3. For connection to an AVB network, and to be remotely controlled by LA Network Manager.

### LA4X audio and network connection panels

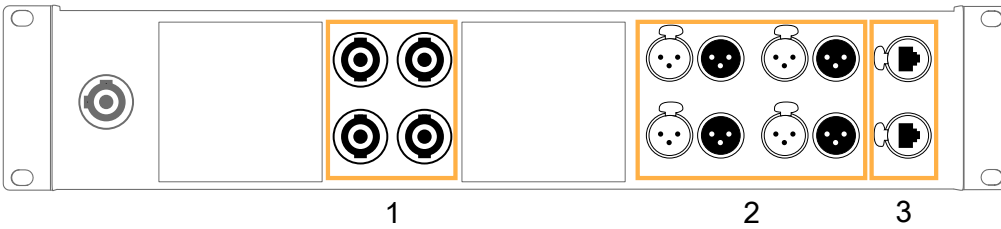

### LA12X audio and network connection panels

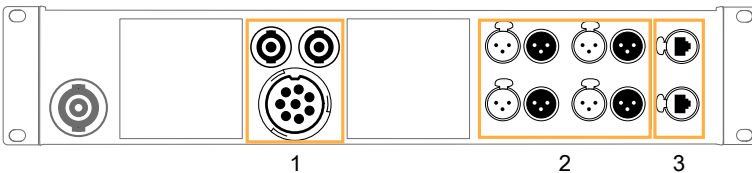

### LA2Xi audio and network connection panels

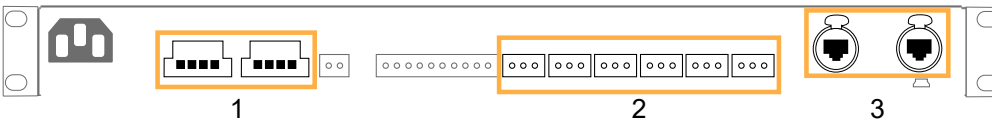

### LA7.16i audio and network connection panels

